

316SS Spring

Part Number	Material	Finish
X1402-01	316SS	mill



316SS Washer, .63 [15.9] O.D. x .05 [1.3] Thick

Part Number	Material	Finish
X1403-01	316SS	mill



316SS JIC Cover Clamp Screws

Part Number	Size	Material	Finish
X1404-03	1/4-20	316SS	mill
X1405-03	1/4-28	316SS	mill



JIC Quick Release Clamp

Part Number	Material	Finish
2185ZN	steel	yellow zinc chromate
2185SS	304SS	tumbled
2185SS01	316SS	tumbled

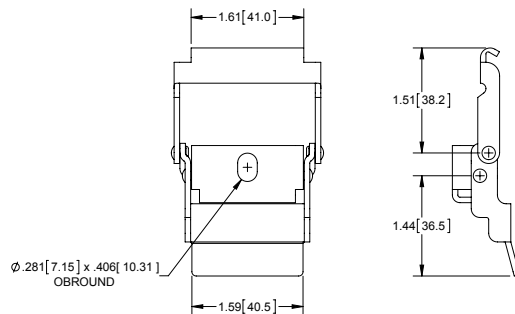
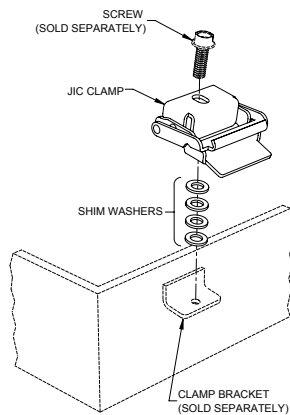

OPEN POSITION

Meter Cover Sealing Ring

Part Number	Component	Description
J2014	Ring	.043 [1.09] aluminum, clear anodized
	Bracket	.043 [1.09] aluminum, clear anodized
	Clip	.093 [2.36] steel, yellow zinc chromate
	Screw	1/4-24 UNS thread steel, yellow zinc chromate

