

Fixed Rod Guide

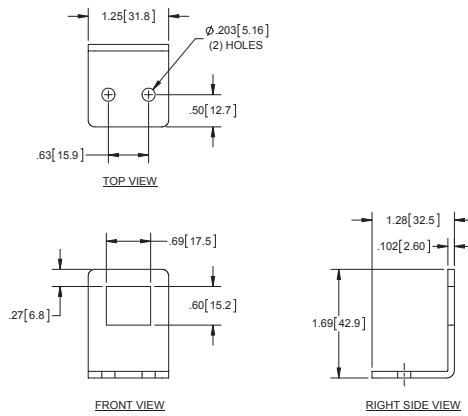

Part Number	Material	Finish
702	steel	zinc plated

▶ use with channel rods on pg. 241

Fixed Rod Guide

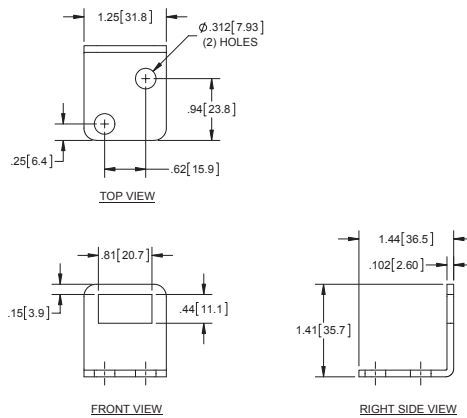

Part Number	Material	Finish
702-01	steel	zinc plated

▶ use with tubular rods on pg. 239

Adjustable Rod Guide

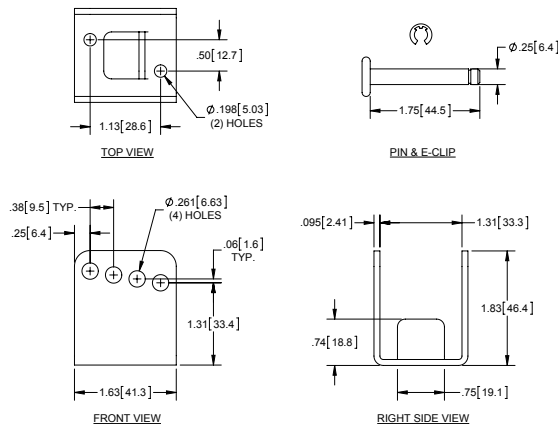

Part Number	Material	Finish
710	steel	zinc plated
710SS	304SS	passivated
710A	aluminum guide & 304SS pin	tumbled
711	steel	mill guide & zinc plated pin

▶ use with tubular rods on pg. 239

Shoulder Bolts for Center Cams

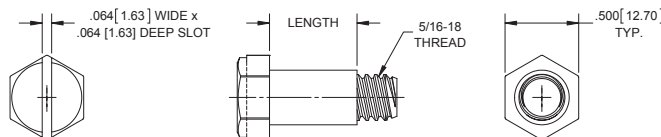

Part Number	Length	Material	Finish
703	.594 [15.09]	steel	zinc plated
760	.391 [9.93]	steel	zinc plated
760SS	.391 [9.93]	304SS	tumbled

▶ part no. **703** is used on channel rods on page 241
 ▶ part no. **760** & **760SS** are used on tubular rods on page 239