

Compression Over-Center Lever Latches 316SS

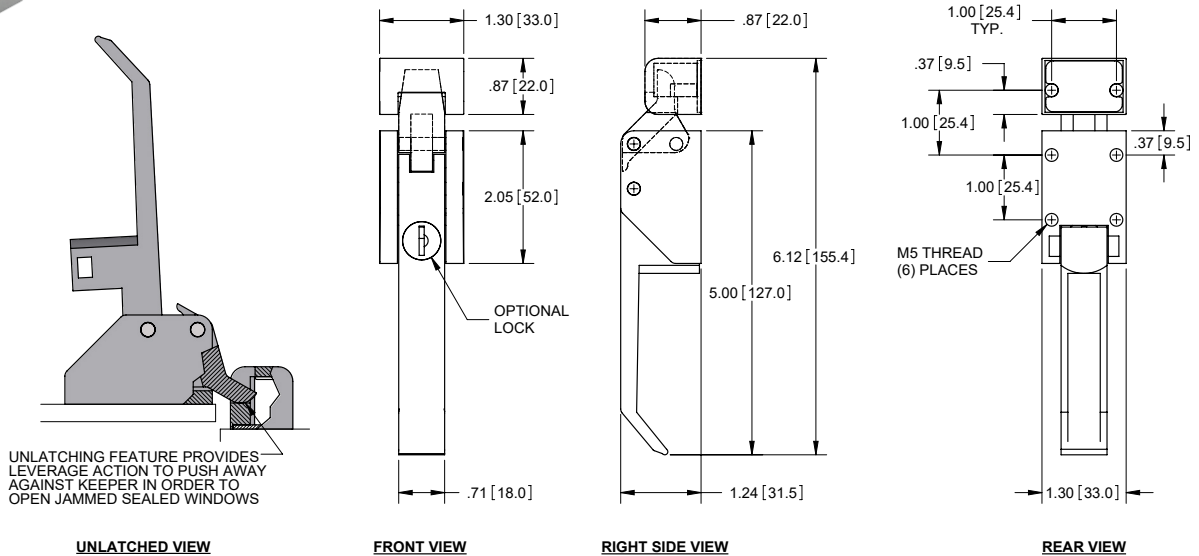

Part Number	Material	Finish	Key Code
173	die cast zinc	black powder coated	non-locking
173LK	die cast zinc	black powder coated	K03
173LK-751	die cast zinc	black powder coated	CH751
173CH	die cast zinc	chrome plated	non-locking
173CH-LK	die cast zinc	chrome plated	CH751
173SST	316SS	brushed	non-locking
173SST-CH751	316SS	brushed	CH751

- ▶ includes keeper and keys (for locking versions)
- ▶ .38 [9.7] stable compression for sealed door latching
- ▶ .31 [7.9] unlatching feature for opening jammed sealed doors



Panel Fastening Concealed Draw Latches



1130-S



1130-L

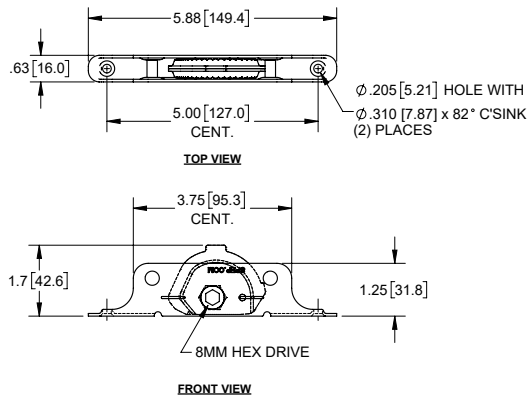

Part Number	Description	Material	Finish
1130-L	latch	steel	zinc plated
1130-S	keeper	steel	zinc plated

- ▶ for drawing panels together
- ▶ provides good gasket compression
- ▶ strong closing pressure with minimal operating force

